

Contents

1 Product

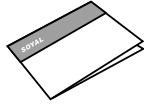

2 User Guide



3 Panel Mounting Base



AR-701B-X
Fit 35mm DIN Rail or Mount directly

Option

4 WG Key-panel Reader



AR-721K



AR-725K



AR-331K

Option

For Stand-alone Command Setting

Specification

CPU	8 bit CPU	Temperature	-20°C ~ +60°C	Event log	1456
RAM	512 k Bits	Digital Input	2 Door Open Button/ 2 Door Sensor/ 2 Housing open detection/ Prepared for 2 DI	Aux. WG Port	WG 26 / WG 34
Power Supply	10 ~ 24	Relay Output	2 Door Relay/ 1 Alarm Relay/ Prepared for 1 Relay output	Anti-pass-back	YES
Power Consumption	< 3W	Transistor Output	Prepared for 2 DO	Lift Control	NO
Interface	RS-485	Door Relay Time	Toggle, 0.1~600Ses	Time Zone	63 (stand-alone /networking)
Baud Rate	9600 bps,N,8,1	Alarm Relay Time	Toggle, 0.1~600Ses	Real Time Clock	YES
External WG Readers	2 WG (Controller power supply)	User Capacity	3,000	DIP_SW	7 (Node ID: 1~128)

Connector Table

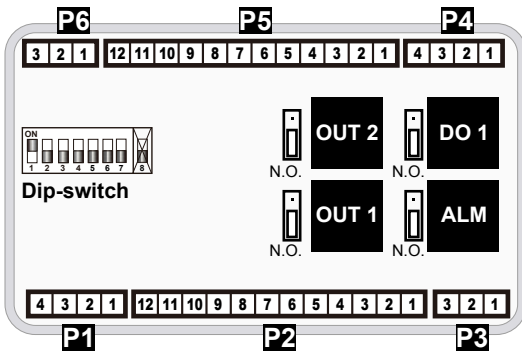

Connector: P1 RS-485 / Power

Code	Pin	Description
LA+	1	RS-485(A+)
LB-	2	RS-485(B-)
GND	3	DC Power 0V
DC 12V	4	DC Power 12V

Connector: P4 Relay / Alarm Output

Code	Pin	Description
DO1	1	N.C./N.O.
COM	2	COM
ALM	3	N.C./N.O.
COM	4	COM

Connector: P2 WG Port 1

Code	Pin	Description
COM	1	COM
OUT1	2	N.C./N.O.
BZ	3	Beeper Output
GLED	4	LED Green Output
RLED	5	LED Red Output
TAM (N.C.)	6	Tamper Switch Input
SEN (N.C.)	7	Door Status Input
PB (N.O.)	8	Exit Button Input
WG1	9	Wiegand DAT:1 Input
WG0	10	Wiegand DAT:0 Input
GND	11	DC Power 0V Output
12V	12	DC Power 12V Output

Connector: P5 WG Port 2

Code	Pin	Description
OUT2	1	N.C./N.O.
COM	2	COM
RLED	3	LED Red Output
GLED	4	LED Green Output
BZ	5	Beeper Output
PB (N.O.)	6	Exit Button Input
SEN (N.C.)	7	Door Status Input
TAM (N.C.)	8	Tamper Switch Input
WG0	9	Wiegand DAT:0 Input
WG1	10	Wiegand DAT:1 Input
12V	11	DC Power 12V Output
GND	12	DC Power 0V Output

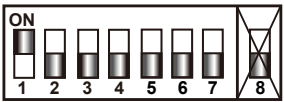

• Node ID is setting by DIP_Switch, Node ID: 01~128

Value	1	2	4	8	16	32	64	
DIP SW	1	2	3	4	5	6	7	8
Node 01	ON	off	off	off	off	off	off	
Node 02	off	ON	off	off	off	off	off	
Node 03	ON	ON	off	off	off	off	off	
⋮								
Node 127	ON	ON	ON	ON	ON	ON	ON	
Node 128	off	off	off	off	off	off	off	

Connector: P3 Digital Input

Code	Pin	Description
GND	1	DC Power 0V Output
DI2	2	DI 2
DI1	3	Fire-alarm Input

Connector: P6 Transistor Output

Code	Pin	Description
DO3	1	DO 3
DO2	2	DO 2
GND	3	DC Power 0V Output

Wiring Diagram

P1 Connect to PC

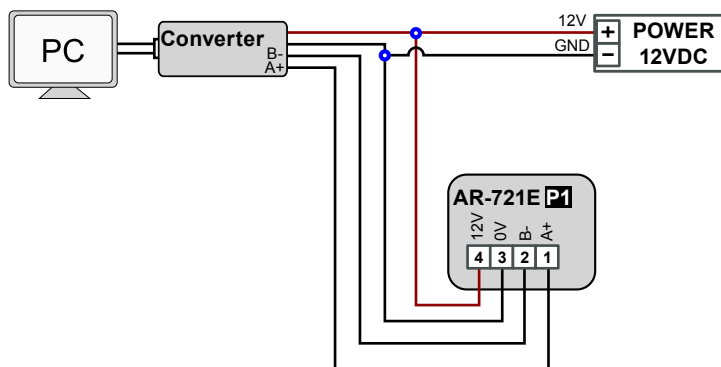

P4 Connect to Alarm or Other Equipment

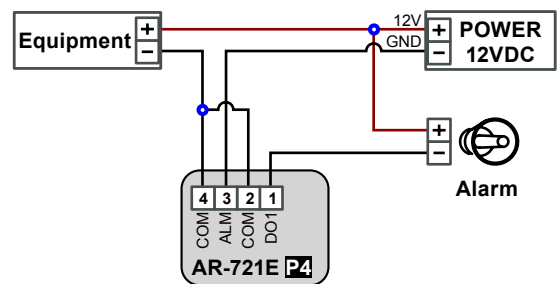

P2 Connect to Electric Strike

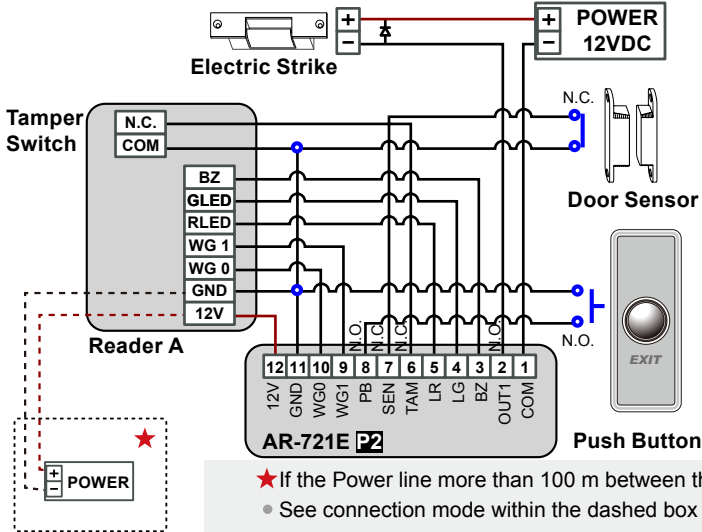

P5 Connect to Magnet Lock or Electric Bolt

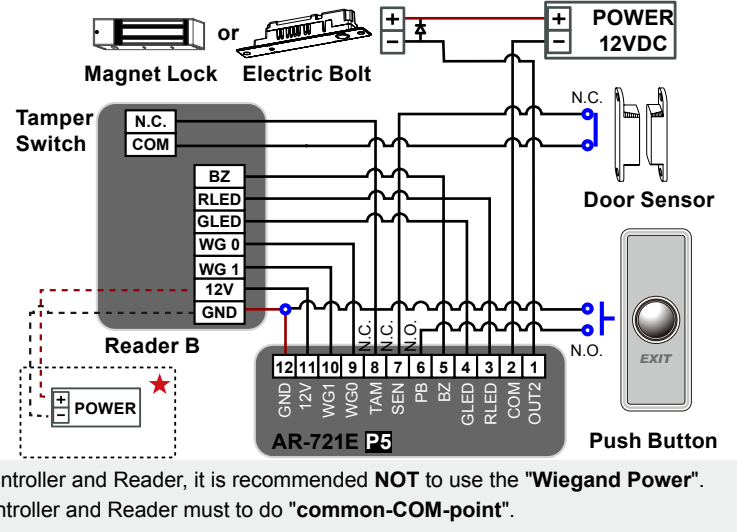

P3 About Digital Input

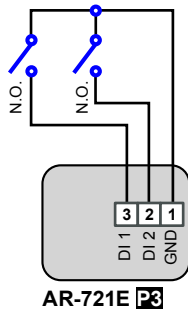

P6 About Transistor Output

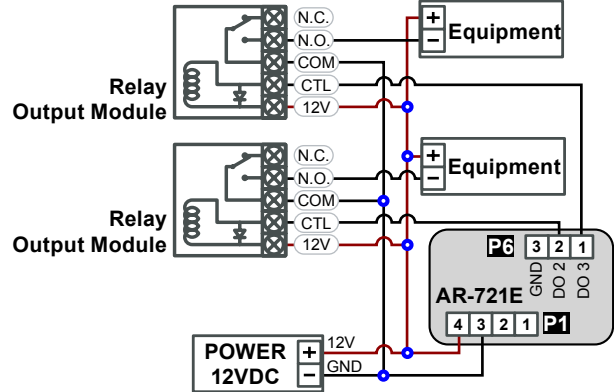

All commands below are only able to set up by connected with WG key-panel reader.

Adding and Deleting Tag

• Add Single Tag or Random tags

Input *123456# (or Master Code) → 19 *UUUUU * 00001# → Present the tag(s) with reader (single tag or random numbered cards one by one) → Done
 [e.g.] 2 random cards with user addresses No. 100 and No. 101:

Access programming mode → 19 * 00100 * 00001# → Present the tags one by one → Done

• Add the Sequential tags

Input *123456# (or Master Code) → 19 *UUUUU * QQQQQ# → Present the tags (Present the tag with the **lowest number** first.) → OK
 [e.g.] User Address NO.101 to NO.120 have 20 pcs of sequential tags:(62312~62332):

Access programming mode → 19 * 00101 * 00120# → Close Tag into RF Area(only use the tag NO.62312) → OK

• Delete a Single Tag

Input *123456# (or Master Code) → 10 *SSSSS 9 EEEEE#

[e.g.] Delete User Address: 00058

Access programming mode → 10 * 00058 9 00058#

• Delete a batch of Tags

Input *123456# (or Master Code) → 10 *SSSSS 9 EEEEE#

[e.g.] Delete User Address: 00101~00245

Access programming mode → 10 * 00101 9 00245#

• Delete All Tags

Input *123456# (or Master Code) → 29 *29 *#

Tag Information

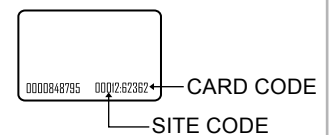
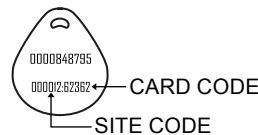

Operation process

A. Enter/ Exit Program Mode

• Enter the program mode

Input *123456# or *PPPPPP#

[e.g.] The Default Value= 123456, if already changed the Master Code= 876112, input *876112# → program mode accessed

• Exit the program mode

Input * #

• Master Code modification

Access programming mode → 09 *PPPPPPRRRRR# [Input the 6-digit new master code twice.]

[e.g.] Set the Master code to be 876112, input *123456# → 09 *876112876112#

B. Chang the Node ID of Reader

Access programming mode → 00 * NNN # [Node ID: 001~255]

C. Set up M4/M8

Access programming mode → 04 * N # [N=4/8]

D. Set up the password

Card or PIN: Access programming mode → 12 * UUUUU * PPPP # [e.g. User address: 00001 and pass code: 1234, input 12 * 00001 * 1234 #]

Card and PIN: Access programming mode → 13 * UUUUU * PPPP # [e.g. User address: 00001 and pass code: 1234, input 13 * 00001 * 1234 #]

E. Anti-pass-back(Reader A and Reader B must to be setting)

Usually, anti-pass-back is commonly applied to parking areas in order to prevent from multi-entry with one card at a time, or to situations need access and exit monitor.

• Controller enable

Access programming mode → 20 * DDD # [128= Anti-pass-back(0=Disable; 1=Enable)/ 064=Access/Exit(0=Exit; 1=Access).]

[e.g.] Enable Anti-pass-back, and set to Exit door=(128 x 1) + (064 x 0) = 128

Access programming mode → 20 * 128 # (Please refer to function default value for details.)

• Card enable

Access programming mode → 26 * SSSSS * EEEEE * N #

[SSSSS= User address start; EEEEE= User address end; N=0(control)/ 1(Not control)/ 2(reset)]

[e.g.] User address from 00152 to 00684 enable the anti-pass-back function: 26 * 00152 * 00684 * 0 #

[e.g.] No. 154 enable the anti-pass-back, and induction into the door has not been induced to leave. When he re-induction into the door will become invalid, then he needs to set the reset. Access programming mode → 26 * 00154 * 00154 * 2 # → Reset

F. Auto Open Time Zone

Door will keep open after the first flashing card. There are 2 time zones supported.

• Enable/Disable auto open zone

Access programming mode → 20 * 004 # [004= enable Auto-Open Time Zone; 000= disable Auto-Open Time Zone]

• Enable/Disable auto open door without presenting card

Access programming mode → 24 * 001 # [001= enable Auto-Open Time Zone; 000= disable Auto-Open Time Zone]

• Set up open time

Access programming mode → 08 * N * HHMMhhmm * 6543217H #

N: 2 sets of auto-open zone (N=0=1st set; N=1=2nd set)

HHMMhhmm=Starting time to ending time (e.g. 08301200=08:30 to 12:00)

6543217H= 7 days of week (Sat/Fri/Thu/Wed/Tue/Mon/Sun) + Holiday (F= 0: disable; 1: enable); Holidays establish by the software.

[e.g.] To set the second time zone as 9:30 AM to 4:20 PM, Monday, Wednesday and Friday: 08 * 1 * 09301612 * 01010100 # → Done

G. Setting Up the Arming

• Alarm conditions:

1. Arming is enabled
2. Alarm system connected

• Application:

1. **Door open too long:** Door is open longer than door relay time plus door close time.
2. **Force open** (Opened without a valid user card): Access by force or illegal procedure.
3. **Door position abnormal:** When power is off and then on, reader on arming before power off.

• Enable/Disable Arming status (Factory default armingcode is: 1234) :

Standby Mode

After door open

Door is not open

The normal procedure to open door → Input 4 digit arming code → #

* → Input 4 digit arming code → Present valid card

Enter Program Mode

Enable: Access programming mode → * * #

Disable: Access programming mode → * #

※ [The normal procedure to open door] can refer to [Access Mode].

Function Default Value

20 * DDD

※Default Value

Function	Selection		Bit	Value	Application
Attendance	※0: Yes	1: No	0	001	Networking
Auto Re-lock	※0: Disable	1: Enable	1	002	Networking/Stand-Alone
Auto Open	※0: Disable	1: Enable	2	004	Networking/Stand-Alone
Door open button input	0: Disable	※1: Enable	4	016	Networking/Stand-Alone
Master Reader of Network	※0: Slave	1: Mater	5	032	Networking
Access/Exit	※0: Exit	1: Access	6	064	Networking
Anti-pass-back	※0: Disable	1: Enable	7	128	Networking

24 * DDD

※Default Value

Function	Selection		Bit	Value	Application
Auto-open door without cards at auto open zone	※0: Disable	1: Enable	0	001	Networking/Stand-Alone
Stop Alarm by door close or by push button	※0: None	1: Yes	6	064	Networking/Stand-Alone

2 Door WG Controller

28 * DDD

※Default Value

Function	Selection		Bit	Value	Application
Can be password-free in the Card or PIN mode	※0: Disable	1: Enable	5	032	Networking/Stand-Alone
Reset the Anti-pass-back by the software	※0: Disable	1: Enable	6	064	Networking/Stand-Alone
Arming for force open	※0: Disable	1: Enable	7	128	Networking/Stand-Alone

Selection= 0(none value)/ 1(1 x each value)

[e.g.] DDD value of Enable "Auto Open" + "Exit by Push Button" + "Anti-pass-back" =004+016+128=148;

As a result of that, the command will be 20 * 148 #.

Mode4/ Mode8

- **Mode 4:** 1.Card only; 2.Card and PIN (4-digit PIN) + # ; 3.Card or User address (5-digit) + Individual PIN (4-digit individual PIN) + #
- **Mode 8:** 1.Card only; 2.Card and PIN (4-digit individual PIN) + # ; 3.Card or PIN (4-digit individual PIN)

Command List

※ General instructions

Function	Command	Description	Notes
Entering programming mode	* P P P P P #	PPPPPP=Master Code, default value=123456	
Exiting programming mode	* #		
Control mode setting	04 * N #	N=Mode 4=Mode4 ; 8=Mode8	
Master card setting	07 * S S S S * E E E E E #	SSSSS-EEEEEE=00000-02999; SSSSS=Starting user address; EEEEE=Ending user address	
Auto-open time zone setting	08 * N * H H M M h h m m * 6 5 4 3 2 1 7 H #	N= 0(1st time zone) / 1(2nd time zone) HHMM= Starting time; hhmm= ending time (i.e.: 08301200=08:30 to 12:00) 6543217H= 7 days of week (Sat/Fri/Thu/Wed/Tue/Mon/Sun) + Holiday (F= 0: disable; 1: enable); Holidays establish by the software.	
Master code setting	09 * P P P P P R R R R R R #	PPPPPP=New master code RRRRRR=Repeat the new master code	
Suspend / Delete tag	10 * S S S S * E E E E E # 10 * S S S S 9 E E E E E #	* =Suspend 9 =Delete; SSSSS=Starting user address, EEEEE=Ending user address	
Active the suspended cards	11 * S S S S * E E E E E #	SSSSS=Starting card number, EEEEE=Ending card number	
Set the cards as Card mode OR PIN mode by user address	12 * U U U U U * P P P P #	Access mode: Card or PIN ; UUUUU=user address; PPPP=4-digit pass code 0001~9999	
Set the cards as Card AND PIN mode by user address	13 * U U U U U * P P P P #	Access mode: Card and PIN ; UUUUU=user address; PPPP=4-digit pass code 0001~9999	
Duress code setting	15 * P P P P #	PPPP=4-digit pass code (default value=4321) PS. Duress code will be unavailable and become a public PIN at access mode "Card or PIN" of M6	
Card number modification	16 * U U U U U * S S S S C C C C C #	UUUUU= User address; SSSSS=5-digit site code; CCCCC=5-digit card code	
Arming pass code setting	17 * P P P P #	PPPP=4-digit pass code (default value=1234; disable Arming PWD=0000) PS. Arming PWD code will be unavailable and become a public PIN at access mode "Card PIN" and of M6	
Door open waiting time	18 * T T T #	TTT=Door open waiting time: 001~600=1~600 sec.; default value: 15 sec.	
Set the card by induction(M4/M8)	19 * U U U U U * Q Q Q Q Q #	UUUUU=User address(Range: 00000~02999); QQQQQ=Card quantity(0001=Continuously inducting)	
Controller parameter setting	24 * D D D #	Please refer to function default value for details.	
Controller time clock setting	25 * Y Y M M D D H H m m s s #	YYMMDDHHmms: Year/ Month/ Day/ Hour/ Min./ Sec.	
Anti-pass-back (Enable user)	26 * S S S S * E E E E E * N #	SSSSS=Starting user address; EEEEE=Ending user address; N=0/Enable; N=1/Disable; N=2/Initial	
Controller control setting	28 * D D D #	Please refer to function default value for details.	
Delete all tags	29 * 29 * #		

※ Individual instruction set

Function	Command	Description	Notes
Keyboard Lock/ Unlock	* #	Press and hold for 2 seconds to lock the keyboard, again to unlock.	
Exiting programming mode and enabling arming status	* * #		
Node ID setting (for Reader)	00 * N N N #	NNN=Node ID, range: 001~254	
Door relay time setting	02 * T T T #	TTT=Door relay time 000= Output constantly 001~600=1~600 sec. 601~609=0.1~0.9 sec.	
Alarm relay time setting	03 * T T T #	TTT=Alarm relay time 001~600=1~600 sec.	
Controller additional setting	20 * D D D #	Please refer to function default value for details.	



1141 Budapest, Fogarasi út 77. **1095 Budapest, Mester utca 34.**
Tel.: *220-7940, 220-7814, 220-7959, Tel.: *218-5542, 215-9771, 215-7550,
220-8881, 364-3428 Fax: 220-7940 216-7017, 216-7018 Fax: 218-5542
Mobil: 30 531-5454, 30 939-9989 Mobil: 30 940-1970, 20 949-2688

www.soyal.hu

E-mail: info@delton.hu Web: www.delton.hu